

BACK

FRONT

1

2

2

3

4

5

6

7

8

9

This page is intentionally left black

AFTER SALES SUPPORT  
 ☎ 1300 296 699  
 AUS Hotline Costs

www.ayonz.com  
 MODEL: UX10000PBQi PRODUCT CODE: 11387 08/2019

**1**  
YEAR WARRANTY

**SUPPORT**  
 info@ayonz.com  
 1300 296 699

UX  
 URBANWORX

**INSTRUCTION MANUAL**  
 UX10000PBQi



**General Safety**  
 Read this manual thoroughly before you start using the Powerbank. Store this manual, the completed warranty card, your receipt and the product packaging. The safety precautions instructions reduces the risk of fire, electric shock and injury when correctly complied to. Please follow all instructions and take notice of all warnings.

**To reduce the risk of injury:**

- Keep batteries out of reach of children.
- Do not heat, open, or dispose of battery pack in fire.
- Do not allow metal objects to touch or pierce the battery in the device.
- Do not expose battery pack to excessive heat and direct sunlight.

**CAUTION:**

- Incorrect usage of this power bank may result in battery leakage, overheating, or explosion. Released battery fluid is corrosive and can be toxic. It can cause skin and eye burns, and is very harmful if swallowed.

**How to use**  
**Charging your Wireless Power Bank:**

- Insert USB Cable USB A into a powered device such as an adaptor shown to the right:
- Plug the Micro USB cable side into the Wireless Powerbank, the blue light flashes to indicate the current power level.

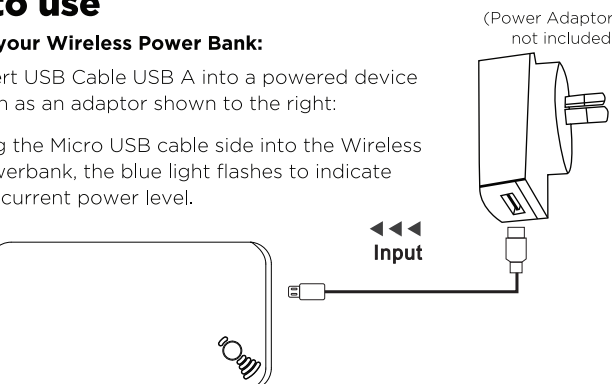

AFTER SALES SUPPORT  
 ☎ 1300 296 699  
 AUS Hotline Costs

www.ayonz.com  
 MODEL: UX10000PBQi PRODUCT CODE: 11387 08/2019

**1**  
YEAR WARRANTY

**Wireless Charging:**

- Place back of your Wireless Charging supported smartphone or device to the back of the Portable Wireless Charger with the suction caps to grip onto your device.
- When charging has commenced on your smart device, the **Indicator A** Light will turn green on the Wireless Portable Charger. (shown below).

**NOTE:** if nothing happens, then your smart device may not have wireless charging capabilities.

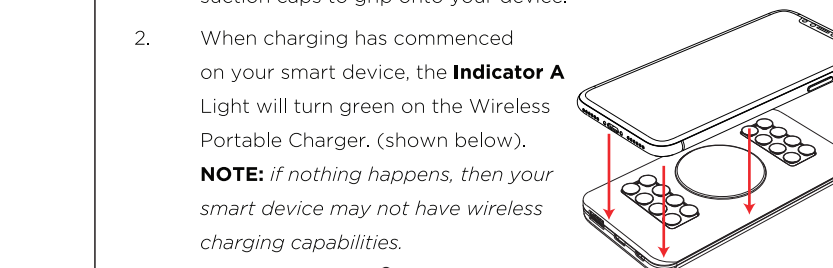

**Battery Indicator:**

● 1	● 2	● 3	● 4
0%-25%	25%-50%	50%-75%	75%-100%

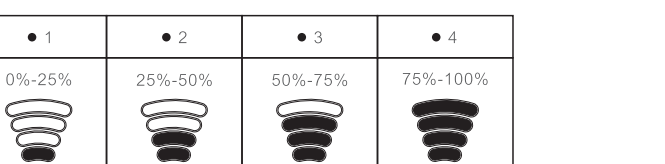

AFTER SALES SUPPORT  
 ☎ 1300 296 699  
 AUS Hotline Costs

www.ayonz.com  
 MODEL: UX10000PBQi PRODUCT CODE: 11387 08/2019

**1**  
YEAR WARRANTY

**Charging your Device:**

- Insert USB Cable USB A into portable wireless charger such as an adaptor shown to the right:
- Plug the Micro USB cable side into the device that needs charging. The blue light flashes to indicate the current power level.

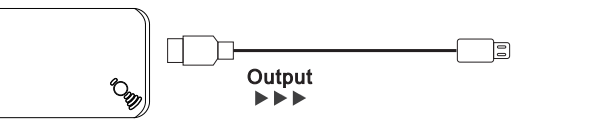

**Accessories:**  
 Wireless Power Bank x1  
 Micro USB Charging Cable x1  
 User Manual x1

**Indicators:**  
 Blue light flashes: charging  
 Blue light on: discharging

Red light on: wireless charging stand-by  
 Green light on: wireless charging  
 Red and Green light fast blink: abnormal operation

**SPECIFICATION**  
 Capacity: 10,000mAh  
 Case: Li-Polymer, Grade A  
 Charging Efficiency: >75%  
 Size: 77(w) x 19(d) x 150(h) mm  
 Weight: Net: 0.28 kg / Gross: 0.4 kg

Input: Micro: DC 5V/2A, DC 9V/2A / Type: C: DC 5V/2.5A/9V/2A  
 USB/Type-C Output: DC 5V/5.1A, DC 9V/2A, DC 12V/1.5A  
 Wireless Output: DC 5V/1A, DC 9V/1.12A (10W)  
 Wireless Power: 10W / 7.5W / 5W

AFTER SALES SUPPORT  
 ☎ 1300 296 699  
 AUS Hotline Costs

www.ayonz.com  
 MODEL: UX10000PBQi PRODUCT CODE: 11387 08/2019

**1**  
YEAR WARRANTY

**DISCLAIMERS:**

- Do not lift powerbank to lift smart device.
- When charging, Do not only hold the Wireless Portable Power Bank. Be sure to hold both the smart device and the Wireless Portable Power bank. Be sure to wrap your hands around and hold both devices together.
- Wireless charging and suction caps only work with certain types and thickness of cases.
- Do not stick suction caps onto the front of smart device.

**OVERVIEW**

- Transmitter Coil Area
- Wireless Charging Status Indicator
- Switch
- Power Level Indicator
- Micro USB Input
- Type-C Input/Output USB Output
- USB Output

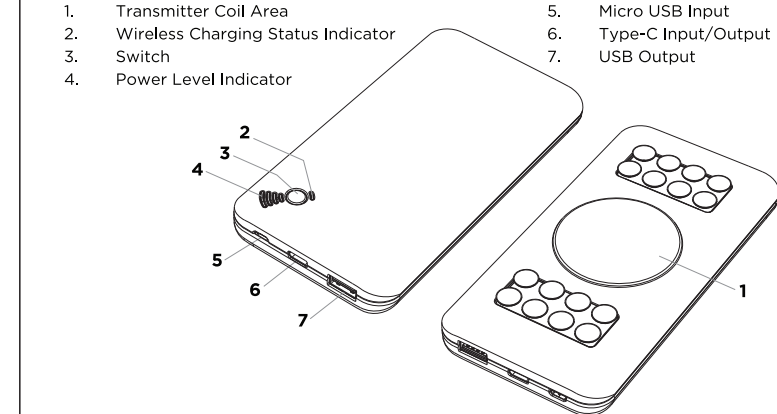

AFTER SALES SUPPORT  
 ☎ 1300 296 699  
 AUS Hotline Costs

www.ayonz.com  
 MODEL: UX10000PBQi PRODUCT CODE: 11387 08/2019

**1**  
YEAR WARRANTY

**ALDI**  
 URBANWORX  
 Wireless Powerbank  
**Warranty Details**

REGISTER YOUR PURCHASE AT [www.aldi.com.au/en/uboot-aldi/product-registration/](http://www.aldi.com.au/en/uboot-aldi/product-registration/) TO KEEP UP-TO-DATE WITH IMPORTANT PRODUCT INFORMATION

The product is guaranteed to be free from defects in workmanship and parts for a period of 12 months (dependent on product) from the date of purchase. Defects that occur within this warranty period, under normal use and care, will be repaired, replaced or refunded at our discretion. The benefits conferred by this warranty are in addition to all rights and remedies in respect of the product that the consumer has under the Competition and Consumer Act 2010 and similar state and territory laws.

Our goods come with guarantees that cannot be excluded under the Australian Consumer Law. You are entitled to a replacement or refund for a major failure and for compensation for any other reasonably foreseeable loss or damage. You are also entitled to have the goods repaired or replaced if the goods fail to be of acceptable quality and the failure does not amount to a major failure.

AFTER SALES SUPPORT  
 ☎ 1300 296 699  
 AUS Hotline Costs

www.ayonz.com  
 MODEL: UX10000PBQi PRODUCT CODE: 11387 08/2019

**1**  
YEAR WARRANTY

**ALDI**  
 URBANWORX  
 Wireless Powerbank  
**Repair and Refurbished Goods or Parts Notice**

Unfortunately, from time to time, faulty products are manufactured which need to be returned to the Supplier for repair.

Please be aware that if your product is capable of retaining user-generated data (such as files stored on a computer hard drive, telephone numbers stored on a mobile telephone, songs stored on a portable media player, games saved on a games console or files stored on a USB memory stick) during the process of repair, some or all of your stored data may be lost. **We recommend you save this data elsewhere prior to sending the product for repair.**

You should also be aware that rather than repairing goods, we may replace them with refurbished goods of the same type or use refurbished parts in the repair process. **Please be assured though, refurbished parts or replacements are only used where they meet ALDI's stringent quality specifications.**

If at any time you feel your repair is being handled unsatisfactorily, you may escalate your complaint. Please telephone us on SUPPLIER TELEPHONE or write to us at:

**Ayonz Pty Ltd**  
 Unit 40, 11-21 Underwood Road,  
 Homebush, 2140, NSW, Australia  
 1300 296 699  
 info@ayonz.com

**Helpline hours of operation:**  
 Mon-Fri: 9:00am - 5:00pm  
 (Including Public Holidays)

AFTER SALES SUPPORT  
 ☎ 1300 296 699  
 AUS Hotline Costs

www.ayonz.com  
 MODEL: UX10000PBQi PRODUCT CODE: 11387 08/2019

**1**  
YEAR WARRANTY

This page is intentionally left black

AFTER SALES SUPPORT  
 ☎ 1300 296 699  
 AUS Hotline Costs

www.ayonz.com  
 MODEL: UX10000PBQi PRODUCT CODE: 11387 08/2019

**1**  
YEAR WARRANTY

This page is intentionally left black

AFTER SALES SUPPORT  
 ☎ 1300 296 699  
 AUS Hotline Costs

www.ayonz.com  
 MODEL: UX10000PBQi PRODUCT CODE: 11387 08/2019

**1**  
YEAR WARRANTY

This page is intentionally left black

AFTER SALES SUPPORT  
 ☎ 1300 296 699  
 AUS Hotline Costs

www.ayonz.com  
 MODEL: UX10000PBQi PRODUCT CODE: 11387 08/2019

**1**  
YEAR WARRANTY